

SPECIFICATION

Product Name: Single Beam NDIR CO₂ Sensor Module

Item No.: CM1106-C

Version: V0.6

Date: June 18, 2021

Revision

No.	Version	Content	Date
1	V0.2	1: UART protocol "check sum", the correct content is "Cumulative sum of data = 256-(HEAD+LEN+CMD+DATA)%256" 2: Change the company name to Cubic Sensor and Instrument Co.,Ltd	2019.12.10
2	V0.3	Update the I ² C protocol	2020.01.17
3	V0.4	Update measurement range	2020.06.11
4	V0.5	Update the I2C protocol "measuring result"	2020.07.10
5	V0.6	Update protocol description and package information	2021.06.18

Single Beam NDIR CO₂ Sensor Module

CM1106-C

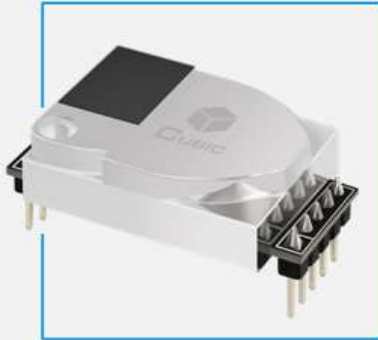

Applications

- HVAC industry
- IAQ monitor
- Air purifier
- Automotive
- IoT devices
- Plant growth

Description

CM1106-C is a single beam NDIR CO₂ sensor module, based on non-dispersive infrared (NDIR) technology, which can detect CO₂ concentration of indoor air. With high accuracy, high stability, small size, it is widely used for ventilation system, air purifier, air conditioner, HVAC transmitter, IAQ monitor, etc.

Features

- NDIR technology with independent intellectual property
- High accuracy, long term stability, long life (>10years)
- Temperature calibration within whole measurement range
- Auto-calibration, no need of maintenance
- Signal output PWM/UART/I²C
- Small size and compact structure, easy to install

Working Principle

The main components of an NDIR CO₂ sensor are an infrared source, a sample chamber, a filter and an infrared detector. The infrared light is directed by the infrared source passing through the gas chamber towards the detector.

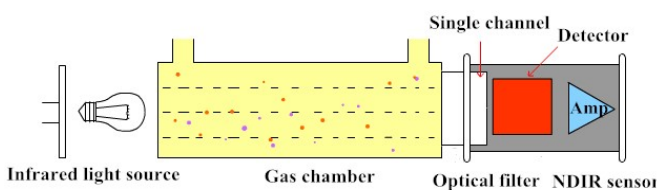

CO₂ molecules inside the gas chamber will only absorb a specific wavelength of the light. The filter allows only the specific wavelength corresponded to pass through it. The detector measures the intensity of infrared light that is related to the intensity of CO₂ and can be described through the Lambert-Beer's Law. The change in sensor signal reflects the change in gas concentration.

Specifications

Single Beam NDIR CO ₂ Sensor Specification	
Target gas	Carbon dioxide (CO ₂)
Operating principle	Non-dispersive infrared (NDIR)
Measurement range	0-5000ppm
Working temperature	-10°C ~ 50°C
Working humidity	0-95%RH (non-condensing)
Storage temperature	-30°C ~ 70°C
Storage humidity	0-95%RH (non-condensing)
Accuracy	± (50ppm+5% of reading) @0°C~50°C, 50±10%RH (Note 1 and 2)
Sampling frequency	1s
Time to first reading	≤30s
Power supply	DC 4.5V-5.5V
Working current	<45mA
Dimensions	33x19.7x8.9mm (pin is not included)
Weight	5g
Signal output	UART_TTL PWM I ² C
PWM output	Output high level minimum duration: 2ms (0ppm)
	Output high level maximum duration: 1002ms (5000ppm)
Alarm output (Reserved)	According to customer's actual usage environment and requirements
Life span	≥10 years

Note 1: In normal IAQ applications, accuracy is defined after minimum three (3) ABC periods of continuous operation with ABC on. Some industrial applications do require maintenance. Contact Cubic for further information.

Note 2: Specification is referenced to certified calibration mixtures. Uncertainty of calibration gas mixtures (±2% currently) is to be added to the specified accuracy for absolute measurement.

Dimensions and Connector

1. Dimensions (Unit mm, tolerance ± 0.2 mm)

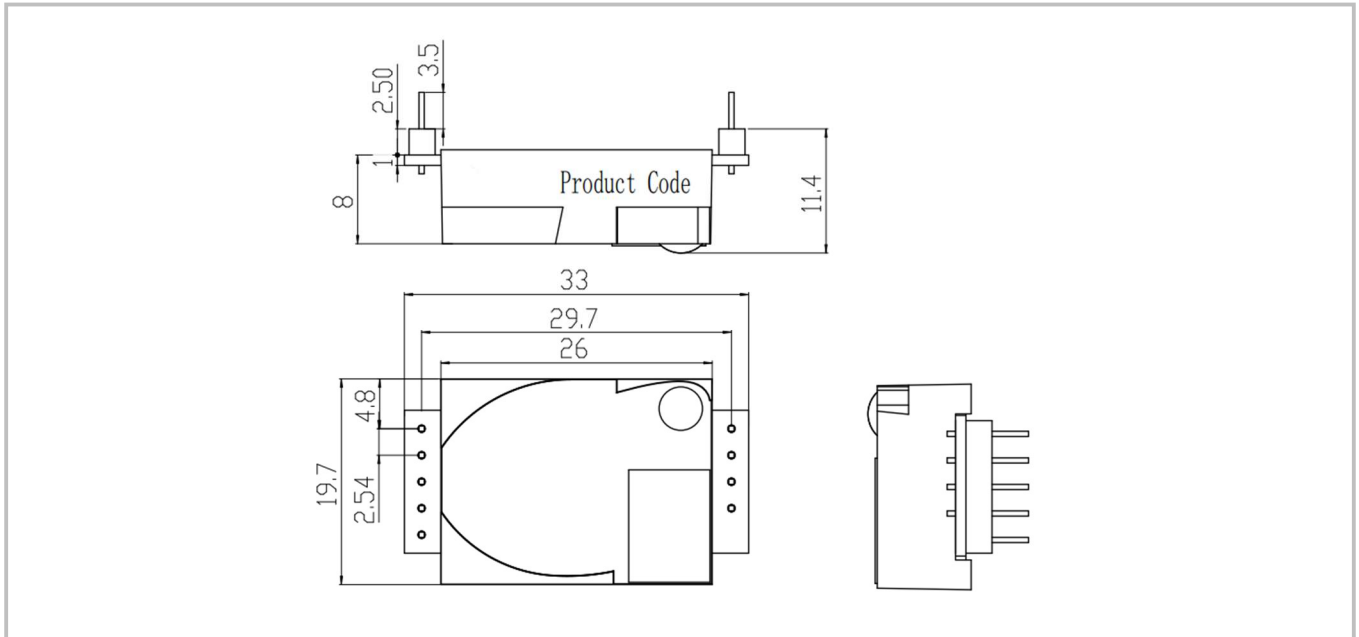

2. I/O Connector Pinout

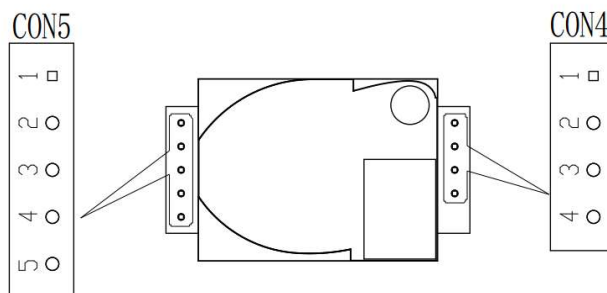

CON5			CON4		
Pin	Name	Description	Pin	Name	Description
1	+3.3V	Power supply output (+3.3V/100mA)	1	+5V	Power supply input (4.5V-5.5V)
2	RX/SDA	UART-RX (Receiving)/I ² C data, compatible with 3.3V and 5V communication	2	GND	Power supply input (GND)
3	TX/SCL	UART-TX (Sending)/I ² C clock, Compatible with 3.3V communication	3	A	Alarming
4	R/T	Output mode exchange: High level or floating is UART communication mode, low level is I ² C communication mode	4	PWM	PWM output
5	CA	Manual calibration			

Typical Application Circuit

Application scene: UART_TTL serial port output

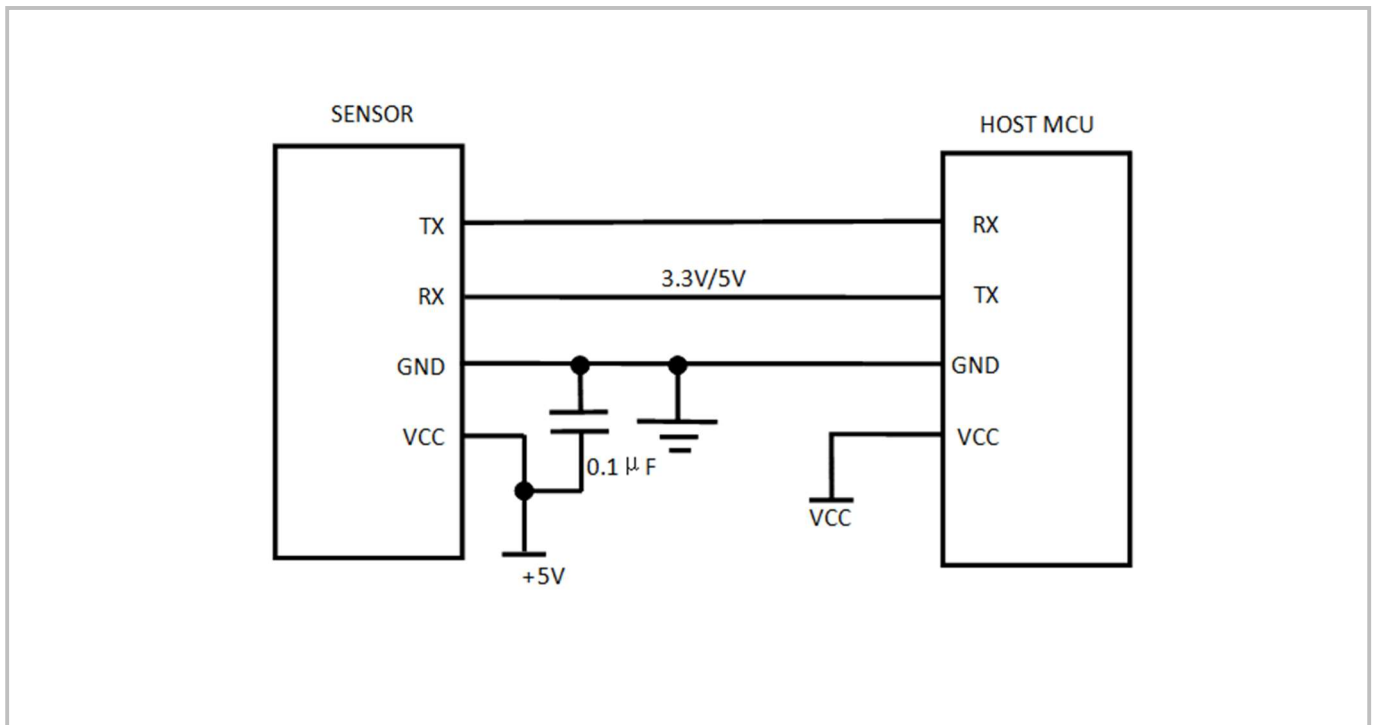

Description of Calibration

Auto Calibration:

Rough installing and influence of transportation might result in reducing of sensor measuring accuracy and baseline drift, sensor will correct the drift by the built-in self-correcting logic, and the auto baseline correction period is 24h+15 days. Powering on the sensor for 24 hours continuously, it will record the lowest CO₂ concentration measurement value during the 24 hours, which will be regarded as baseline (400ppm) when sensor do auto calibration after the 24 hours working, and then the sensor will enter regular 15 days correction cycle, auto calibration will be implemented every 15 days. In order to ensure correct auto calibration, please make sure working environment of the sensor can reach to outdoor fresh air level (400ppm) during the 24 hours and regular 15 days auto baseline correction cycle.

Note: Please contact with Cubic for more detailed auto calibration strategy.

Manual Calibration:

Rough installing and influence of transportation might result in a reducing of sensor reading accuracy and baseline drift. If need to recover accuracy quickly after installing, you can do manual calibration. To put the sensor in the environment where the CO₂ concentration level can reach 400ppm, and to ensure the CO₂ concentration in this environment is stable before calibration. The CA pin of sensor should be well connected at least 2 seconds when doing the manual calibration. Sensor will activate the calibration program after 6 seconds. In addition, sensor also can do manual calibration by sending command, please refer to the communication protocol for more details.

PWM and Alarm Output

PWM cycle: 1004ms

Positive pulse width: 0-5000: (PPM/5) + 2ms

CO₂ concentration detection value: 5000ppm range: (PWM Positive pulse width - 2) * 5

PWM output schema:

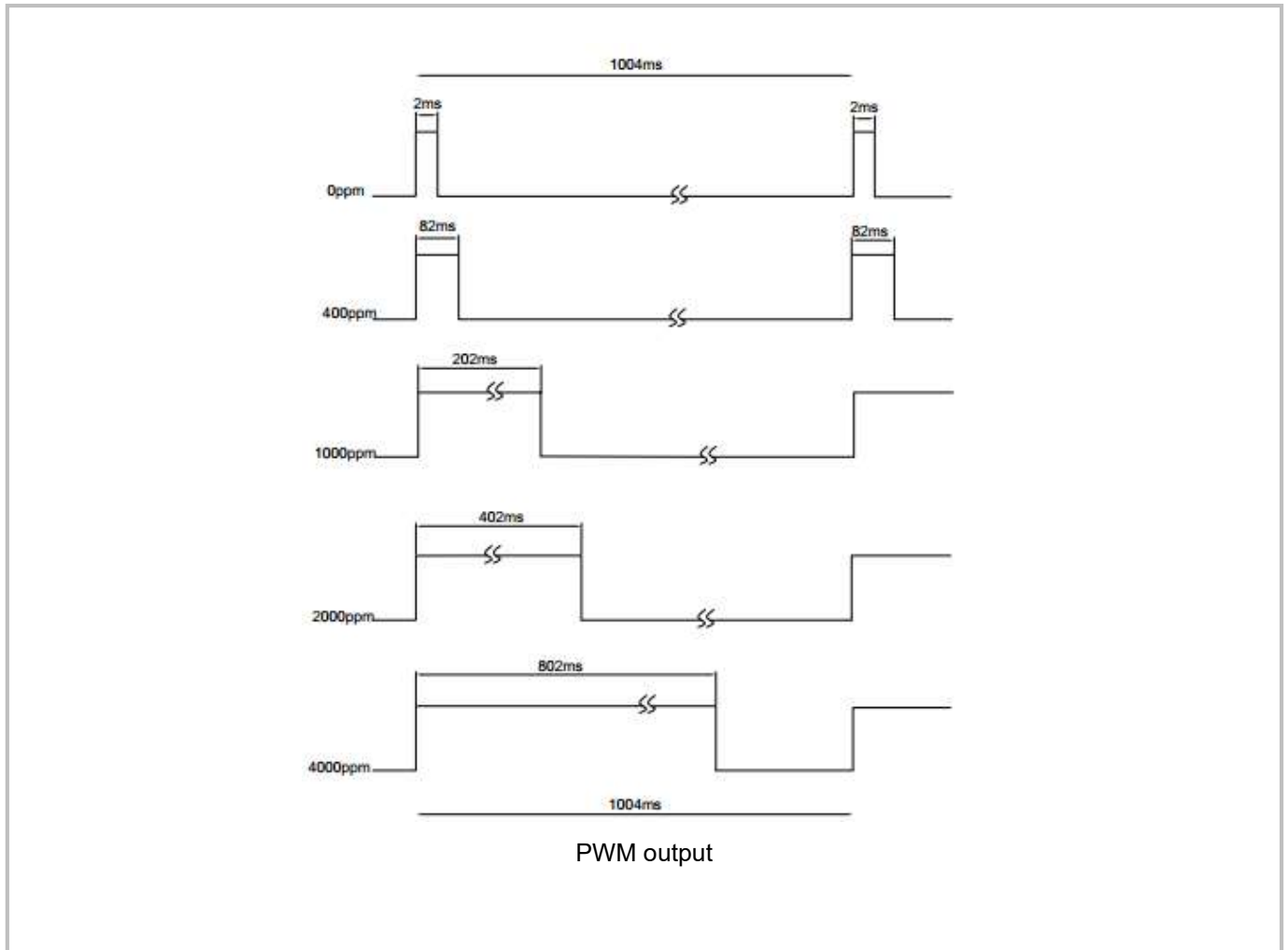

Alarm Output

If the CO₂ concentration rises up to more than 1000ppm, the alarming will be triggered and output high level. When the CO₂ concentration goes down to below 800ppm, the alarming will stop and output low level.

Note

Connect the pin of PWM to the oscilloscope.

Add a pull-up resistor around 5K-10K between the pin of PWM and power supply.

Product Installation

1. In order to ensure airflow diffusion into the sensor inner, make sure the minimum distance between the area of waterproof filter and the other components is 1.5 mm, otherwise, quick response time of the sensor will be affected.

Reference as below:

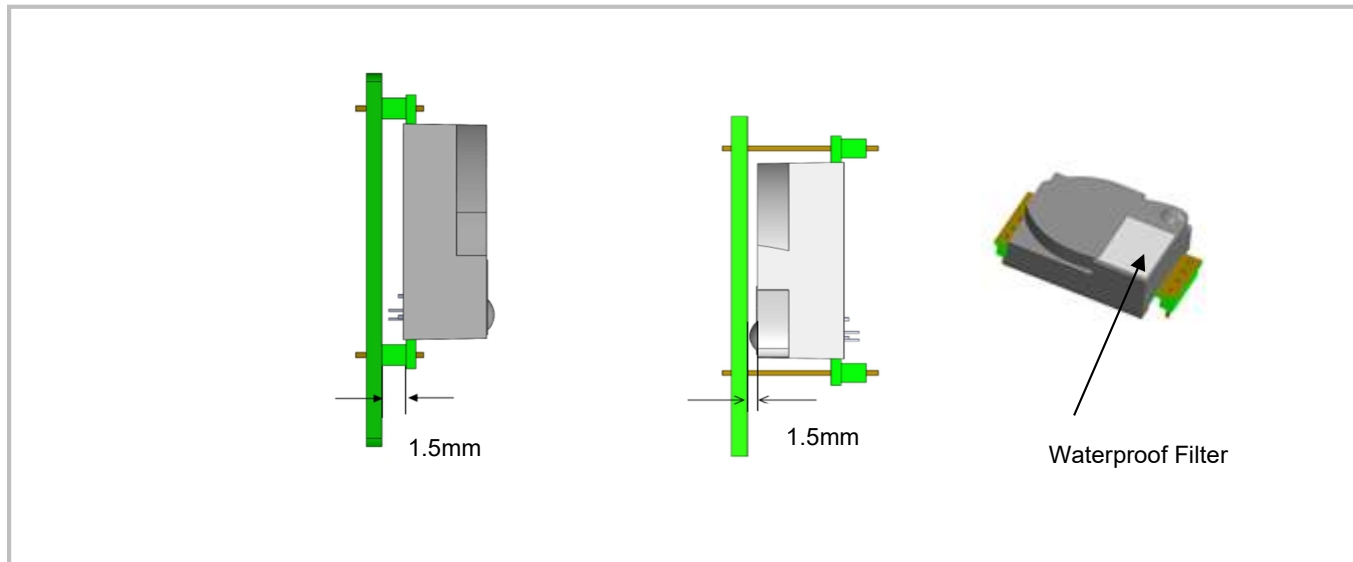

2. To avoid the influence of stress on sensor, please soldering by hand as much as possible when mounting the sensor to the PCB.

Reference as below:

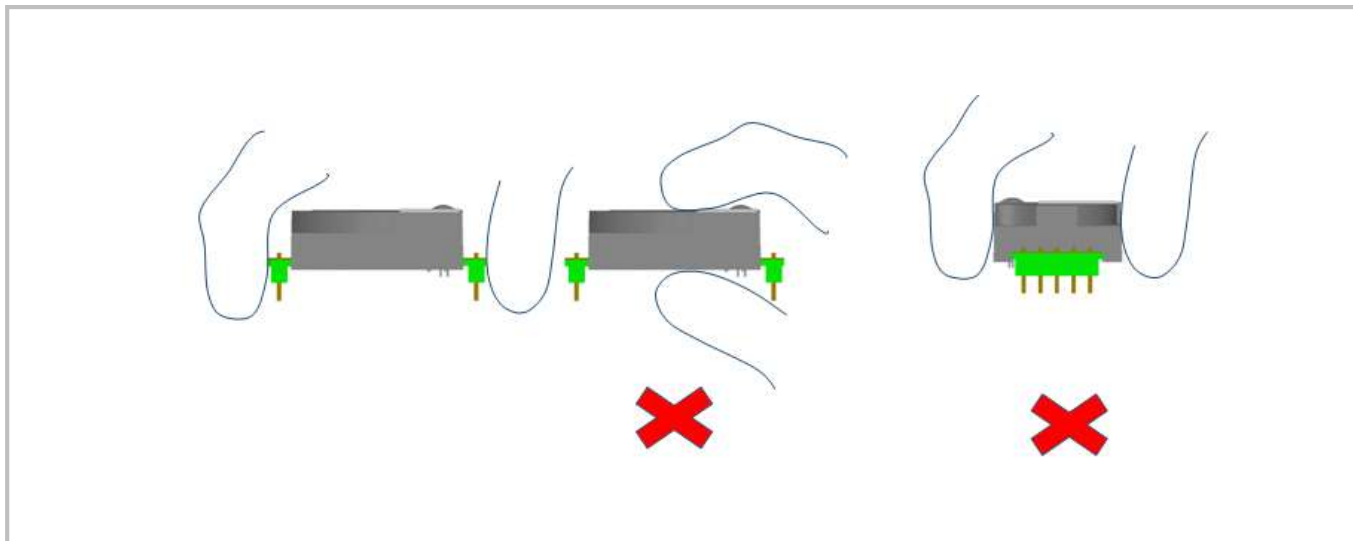

UART Communication Protocol

1. General Statement

- 1). The data in this protocol is all hexadecimal data. Example: "46" for decimal [70].
- 2). Baud rate: 9600, Data Bits: 8, Stop Bits: 1, Parity: No, Flow control: No.
- 3). [x x] is for single-byte data (unsigned, 0-255); for double data, high byte is in front of low byte.

2. Format of Serial Communication Protocol

Sending format of test software:

Start Symbol	Length	Command	Data1	...	Data n.	Check Sum
HEAD	LEN	CMD	DATA1	...	DATAn	CS
11H	XXH	XXH	XXH	...	XXH	XXH

Detail description on protocol format:

Protocol Format	Description
Start Symbol	Sending by test software is fixed as [11H], module response is fixed as [16H]
Length	Length of frame bytes= data length +1 (including CMD+DATA)
Command	Command
Data	Data of writing or reading, length is not fixed
Check Sum	Cumulative sum of data = 256-(HEAD+LEN+CMD+DATA)%256

3. Command Table of Serial Protocol

Item No.	Function Name	Command
1	Read measured result of CO ₂	0x01
2	Open/ Close ABC and set ABC parameter	0x10
3	Calibrate concentration value of CO ₂	0x03
4	Read the serial number of the sensor	0x1F
5	Read software version	0x1E

4. Detail Description of Protocol

4.1 Read Measured Result of CO₂

Send: 11 01 01 ED

Response: 16 05 01 DF1- DF4 [CS]

Function: Read measured result of CO₂ (Unit: ppm)

Note:

CO₂ measured result = DF1*256+DF2

DF3 Status bit: 0: Preheating; 1: Normal operation; 2: Operating trouble; 3: Out of FS, 5: Non-calibrated

DF4 is reserved

Example:

Response: 16 05 01 02 58 00 00 8A

Explanation:

Hex is converted to decimal: 02 is 02; 58 is 88 CO₂ concentration =02*256+88 = 600ppm

4.2 Open/Close ABC and Set ABC Parameter

Send: 11 07 10 DF1 DF2 DF3 DF4 DF5 DF6 CS

Response: 16 01 10 D9

Explanation:

DF1: reserved, default 100 (0x64)

DF2: open/close auto calibration (0: open; 2: close)

DF3: calibration cycle (1-30 days optional, default is 15days)

DF4: High base value (2 bytes) DF5: Low base value (2 bytes)

DF6: reserved, default is 100 (0x64)

Note: The auto calibration function is opened with 15 days calibration cycle by default.

The default value of DF4 and DF5 is 400, that is DF4: 01; DF5:90

4.2.1 Close ABC

In our sensor, the ABC function is default opened status. If you want to close it, you should set the DF2=2.

Example:

Send: 11 07 10 64 02 07 01 90 64 76

Response: 16 01 10 D9

4.2.2 Open ABC and Set Calibration Cycle

When ABC function is closed and you want to re-open ABC function, you should set the DF2=0.

Example: you could send below command to open ABC function and set the calibration cycle 7 days.

Send: 11 07 10 64 00 07 01 90 64 78

Response: 16 01 10 D9

4.2.3 Change the Calibration Cycle

The calibration cycle is 15 days by default. For example, if need to set the cycle to 10 days, then DF3=0A.

Example:

Send: 11 07 10 64 00 0A 01 90 64 75

Response: 16 01 10 D9

4.3 Calibration of CO₂ Concentration

Send: 11 03 03 DF1 DF2 CS

Response: 16 01 03 E6

Function: Calibration of CO₂ concentration

Note:

1. Calibration target value = DF1*256+DF2 Unit: PPM, range (400-1500ppm)
2. Before calibration, please make sure CO₂ concentration in current ambient is calibration target value. Keeping this CO₂ concentration for two 2 minutes, then began calibration.

Example:

When you need to calibrate CO₂ concentration of the sensor to 600ppm, send command:

Send: 11 03 03 02 58 8F

Hex is converted to decimal: 02 is 02; 58 is 88

CO₂ concentration =02*256+88 = 600ppm

4.4 Read the Serial Number of the Sensor

Send: 11 01 1F CF

Response: 16 0B 1F (SN1) (SN2) (SN3) (SN4) (SN5) [CS]

Function: Read the serial number of the sensor

Note: Read the serial number of the sensor. SNn: 0~9999, 5 integer form 20-digit number

4.5 Read Software Version

Send: 11 01 1E D0

Response: 16 0C 1E DF1-DF11 CS

Function: Read software version

Note:

DF1-DF10:stand for ASCII code of software version, DF11 is reserved

Example:

When the sensor version is CM V0.0.20, response data as follows:

Hexadecimal converted to ASCII code:

Note: when 20 converted to ASCII code, it equals to blank space.

16 0C 1E 43 4D 20 56 30 2E 30 2E 32 30 00 97



CM V0.0.20

I²C Communication Protocol

1. Timing Diagram Introduction

1.1 Common Description

- a. This protocol is based on standard I²C timing sequence, the clock frequency is 10kHz~400kHz.
- b. Use big-endian format, the most significant bit to be sent first.

1.2 I²C Sequence Diagram Introduction

Item	Parameter			Unit
	Min	Type	Max	
fSCL (SCL clock frequency)	10		400	KHz
tHD.STA (hold time of the starting bit)		0.6		us
tSU.STA (setup time of the starting bit)		0.6		us
tHD.DAT (hold time of the data)		0		ns
tSU.DAT (setup time of the data)		250		ns
tSU.STO (setup time of the stop bit)		4		us

Note: SCL clock frequency is generated by the master device with the range 10kHz~400kHz.

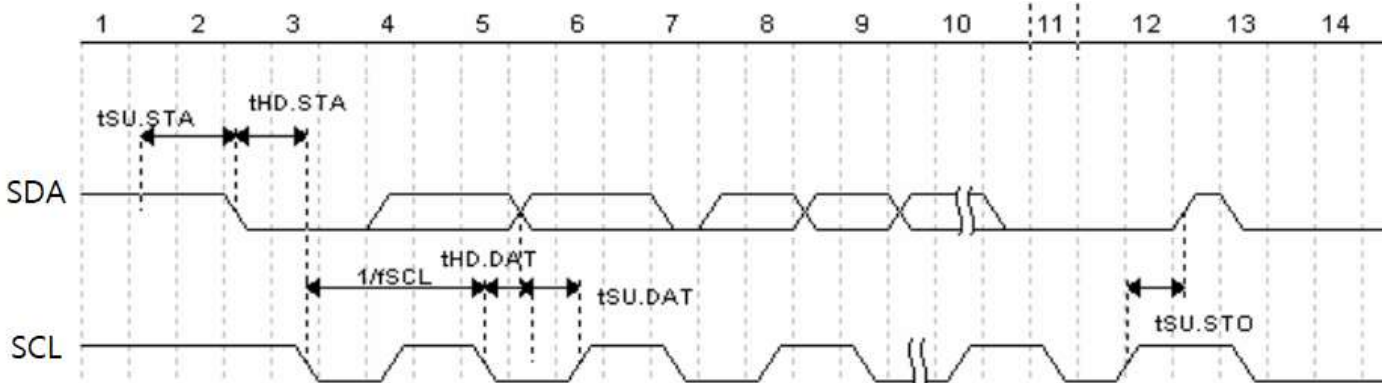

Picture1: I²C clock introduction

1.3 Basic Data Transmission Formats



Picture 2: The general data format sends from the master device to the slave

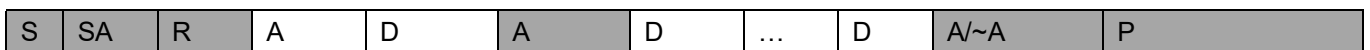

Picture 3: The general data format received from the slave device to the master device

The meaning of the symbol in picture 1.2 and picture 1.3:

- S: start condition
- SA: slave address

- W: write bit
- R: read bit
- A: acknowledge bit
- ~A: not acknowledge bit
- D: data, each data is 8bit
- P: stop condition
- Shadow: The signal generated from the master device
- No Shadow: The signal generated from the slave device

1.4 Timing Diagram

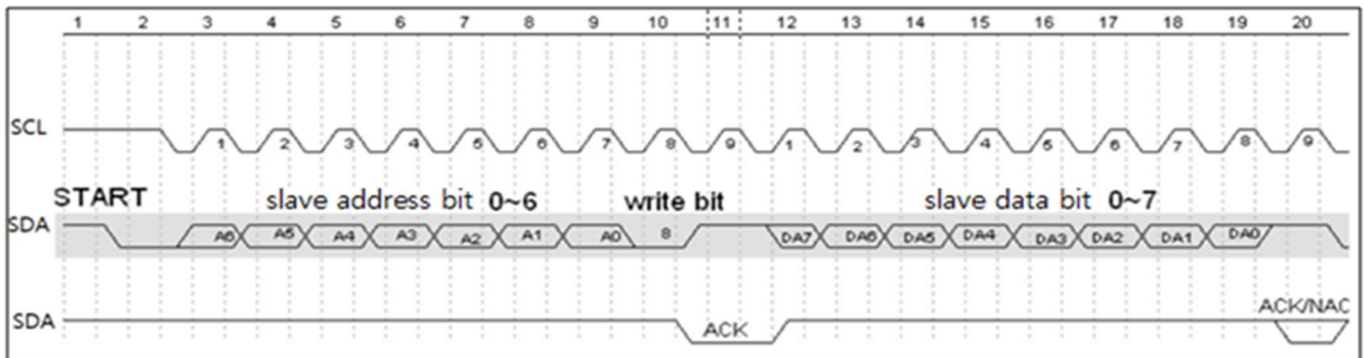

Picture 4: The address byte sent from the master device

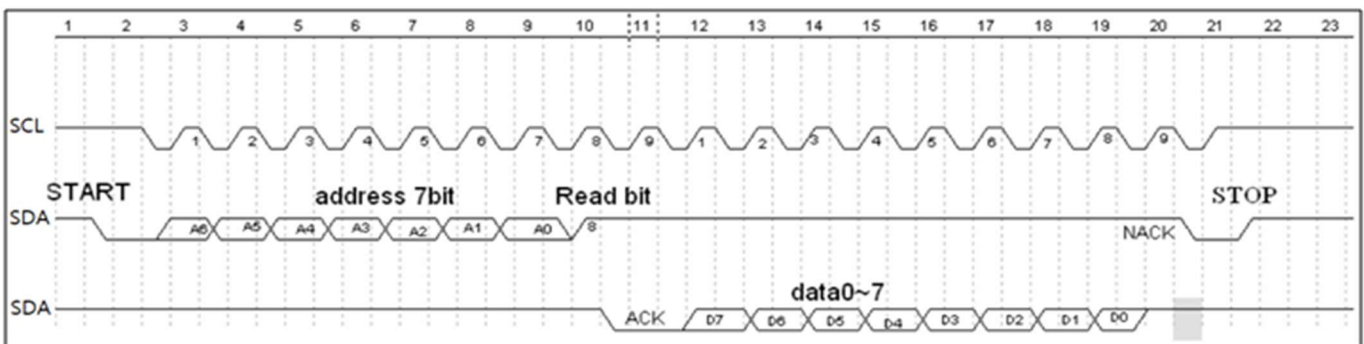

Picture 5: The master device read a byte from the slave device

1.5 Notes

The performance of the MCU which is used in the sensor is not very high. If you use I/O port to simulate I²C master device, it is suggested to reserve a period before and after ACK signal (such as 100 us), after sending every byte (8 bit) to leave enough time for the SCM to process the data. Within requirements of speed, it is recommended to lower the reading speed as much as possible.

2. Measuring Function

Format of command

Format of sending:[CMD][DF0].....[DFn]

[CMD] Command number, for distinguishing different command.

[DF0]..... [DFn] The command with parameter item and optional items.

Format of response: [CMD][DF0]..... [DFn] [CS]
 [CMD]: Command number
 [DF0]..... [DFn]: Effective data
 [CS]: Data check bit = -([CMD]+ [DF0]+.....[DFn]) Only use the lowest bit

2.1 Statement of Measuring Command

The slave address is 0x31, the data command of the slave device is as below:

No.	Function name	CMD	Function description
1	Measure result	0x01	Read measuring result
2	Auto zero setting specification setting	0x10	Set auto zero setting specification
3	Calibration	0x03	Calibration of CO ₂
4	Read the serial number of the sensor	0x1F	Read the serial number of the sensor
5	Check software version	0x1E	Read software version

2.2 Measuring Result

The master device should send command of measuring result.

Send: 0x01

Response: [0x01][DF0][DF1][DF2][CS]

Note:

1. Sensor starts measuring result status once receiving the command 0x01. After this, all the data which I²C read will be such status format data, until the sensor receives new command or re-powering on.
2. Data format, master device receives DF₀ first, and then receives CS at last.

Remark	Status Bite	Decimal Effective Value Range	Relative Value
CO ₂ measuring result	[DF0] [DF1]	0 ~5,000 ppm	0 ~ 5,000 ppm
Status bit	[DF2]		

CO₂ measuring result: DF₀*256+DF₁, Fixed output is 550ppm during preheating period

Status bit: 0: Preheating; 1: Normal operation; 2: Operating trouble; 3: Out of FS, 5: Non-calibrated

Example:

The master device reads some data: Read 3 bit.

0x01 0x03 0x20 0x01 0xDB

CO₂ measuring result = (0x03 0x20)_{hexadecimal} = (800)_{decimal} = 800 ppm

Status bit: 0x01 means working normally

[CS]= -(0x01+0x03+0x20+0x01) Only keep the lowest bite.

2.3 Auto Zero Setting Specification Setting

Send: 0x10 [DF0] [DF1] [DF2] [DF3] [DF4] [DF5]

Response: [0x10] [DF0] [DF1] [DF2] [DF3] [DF4] [DF5] [CS]

Format description:

1. Sensor will be auto calibration specification setting status after receiving command 0x10. After this, all the data which I²C read are the data in this status format, until sensor receives new command or repowering on.
2. Data format, the master will receive [DF0] firstly, and receive [CS] at last.

The result is calculated by high bit in front

Remark	Data Byte	Decimal Effective Value Range	Relative Value
Wrong code accelerate value	[DF0]	By default: 100	100
Zero setting switch	[DF1]	0 or 2	0: Open, 2: Close
Calibration period	[DF2]	1 ~ 30	1 ~ 30
Calibration concentration value	[DF3] [DF4]	400 ~ 1500	400 ~ 1500
Reserved byte	[DF5]	By default: 100	100

2.4 Calibration

The master device should send command of calibration.

Send: 0x03 [DF0] [DF1]

Response: [0x03] [DF0] [DF1] [CS]

Note:

1. Sensor starts calibration status once receiving command 0x03. After this, all the data which I²C read will be such status format data, until the sensor receives new command or re-powering on.
2. Data format, master device receives DF0 first, and then receives CS at last. The result is calculated by high bit in front: [DF0] * 256 + [DF1].

Remark	Data Bite	Decimal Effective Value Range	Relative Value
Adjust value	[DF0] [DF1]	400 ~ 1,500	400 ~ 1,500ppm

2.5 Read the Serial Number of the Sensor

Send: 0x1F

Response: [0x1F] [DF0] [DF1] [DF2] [DF3] [DF4] [DF5] [DF6] [DF7] [DF8] [DF9] [CS]

Note:

1. Sensor starts device code output status once receiving the command 0x1F. After this, all the data which I²C read will be such status format data, until the sensor receives new command or re-powering on.
2. Data format, the master device receives [DF0] first, and then receives [CS] at last. High bit in front.

Remark	Data Bit	Decimal Effective Reading Value Range	Relative Value	Multiple
Integer type 1	[DF0] [DF1]	0 ~ 9999	0 ~ 9999	1
Integer type 2	[DF2] [DF3]	0 ~ 9999	0 ~ 9999	1
Integer type 3	[DF4] [DF5]	0 ~ 9999	0 ~ 9999	1
Integer type 4	[DF6] [DF7]	0 ~ 9999	0 ~ 9999	1
Integer type 5	[DF8] [DF9]	0 ~ 9999	0 ~ 9999	1

3. Five integers form a 20-bit code.

2.6 Read Software Version

Send: 0x1E

Response: [0x1E] [DF0] [DF1] [DF2] [DF3] [DF4] [DF5] [DF6] [DF7] [DF8] [DF9] [CS]

Note:

1. Sensor starts software version output status once receiving the command 0x1E. After this, all the data which I²C read will be such status format data, until the sensor receives new command or re-powering on.
2. Data format, the master device receives DF₀ first, and then receives CS at last. [DF₀] [DF₉] is ASCII.

3. Communication Diagram

Diagram: The master device read two bytes continuously from the slave device.

The slave machine address: 0x31 = 0110001 (the machine address is 7 bit) + read/write bit (1bit)

The slave data address: 0x01 = 00000001

Step 1: The master device sends the address of the slave device+ write bit: 0110001+0 → 01100010 (0x62); at this time, the master device is in sending status.

Step 2: The master device sends the slave data address: 0x01

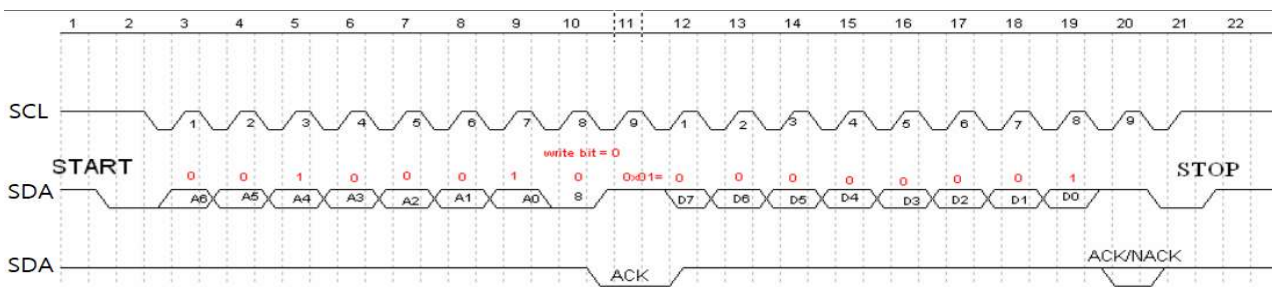

Picture 6: The timing diagram send from the master device

Step 3: The master device send the slave machine address+ read bit: 0110001+1 → 01100011 (0x63); at this time, the master device is in receiving status.

Step 4: The master device sends the answer bit after receiving a one-bit data and the slave continuously sends the next data. If the master device sends the no-answer bit after receiving a one-bit data, then the communication will stop.

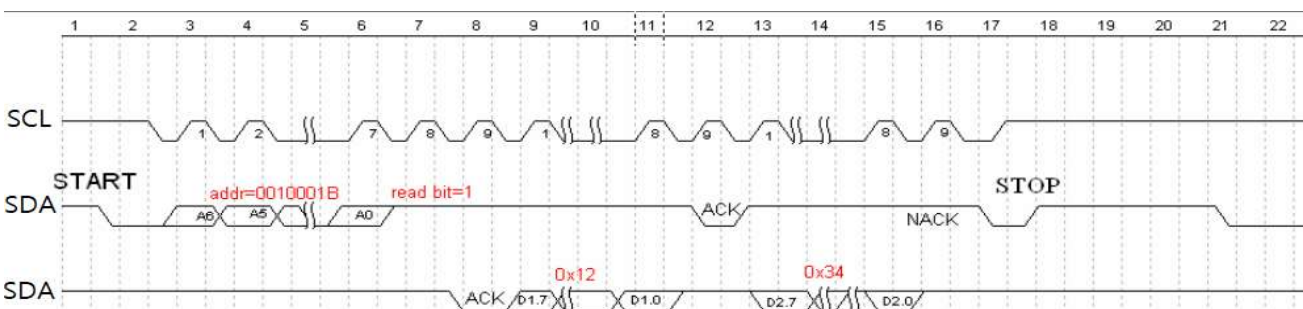

Picture 7: The master device receives the data from the slave device

Packing Information

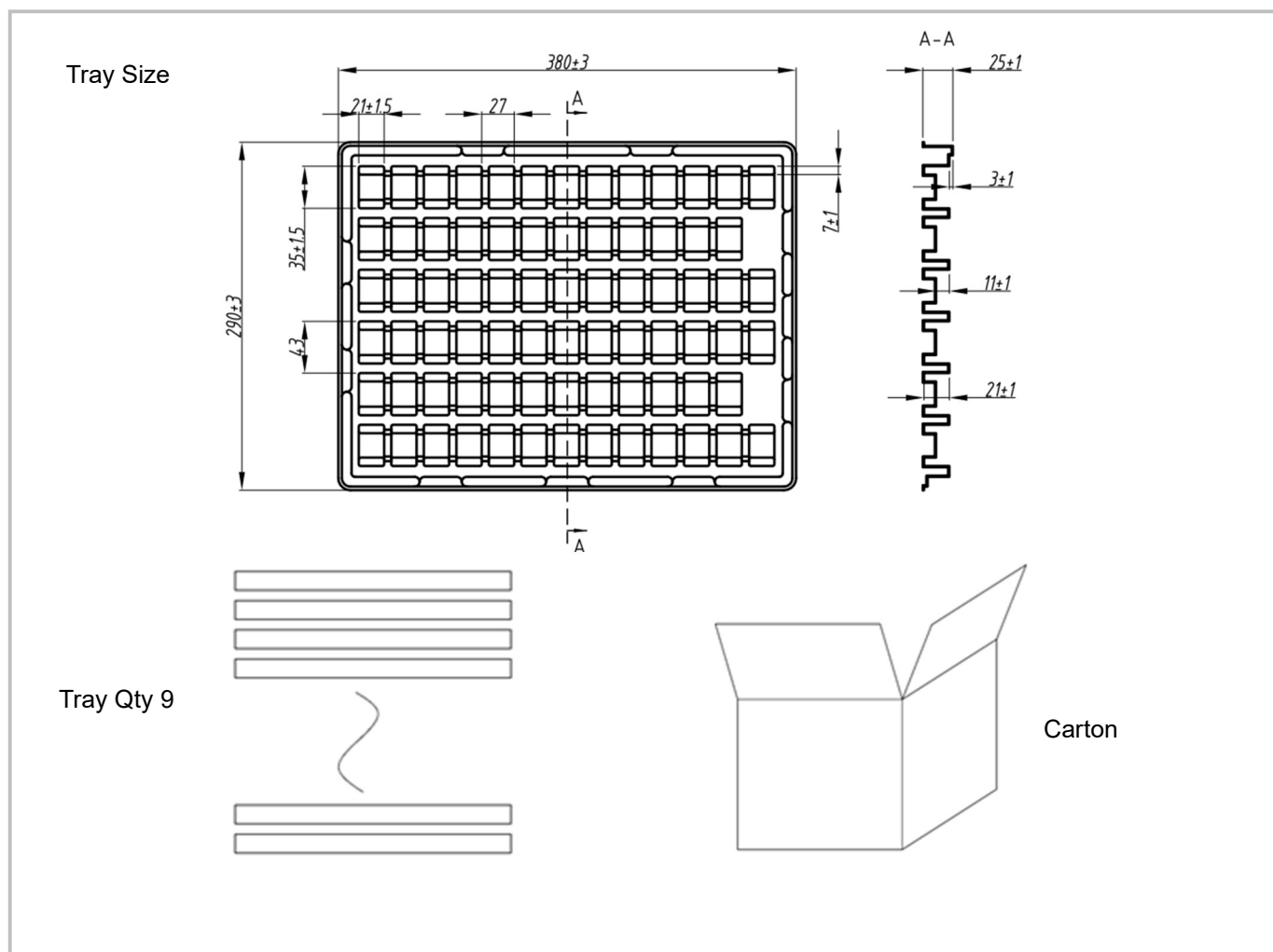

Note: every 3 trays is packed by a plastic vacuum bag.

Sensor per Tray	Tray Qty	Sensor per	Carton Dimensions	Packing Material
70 pcs	9 layers	630 pcs	W395 * L310 * H200 mm	Anti-static PS

After-Sales Services and Consultancy

Cubic Sensor and Instrument Co.,Ltd.

Tel: +86 (0)27 81628827 Fax: +86 (0)27 81628821

Add: Fenghuang No.3 Road, Fenghuang Industrial Park, Eastlake Hi-tech Development Zone, Wuhan 430205, China

E-mail: info@gassensor.com.cn