

SPECIFICATION

Product Name: Ultrasonic Oxygen Sensor

Model No: Gasboard-8500D Series

Version: V0.3

Date: Aug 7, 2019

Revision

No.	Version	Content	Date
1	V0.1	First revision	2018-11-26
2	V0.2	1. Real product photo, physical dimension drawing, pin definition drawing modified by approved products; 2. The detection precision of product specification parameter was modified from " $\pm 1.8\%FS @ (10\sim 45)^{\circ}C$ " to " $\pm 3\%FS @ (5\sim 45)^{\circ}C$ ". Working voltage was modified from "DC 5-12V" to "DC 4.75-12.6V".	2019-3-26
3	V0.3	Specification fonts was modified to Song typeface, Arial.	2019-8-7

Ultrasonic Oxygen Sensor Gasboard-8500D Series



Applications:

- ✧ Family portable oxygen concentrator, medical concentrator, large oxygen concentrator.
- ✧ Family ventilator, medical ventilator.
- ✧ The binary gas (include oxygen) detection.
- ✧ High-flow nasal cannula oxygen therapy ventilation
- ✧ Positive airway pressure ventilation

Description:

Gasboard-8500D series ultrasonic oxygen sensors are an economical gas sensor used to detect oxygen concentration in binary gases. By adopting ultrasonic detecting technology, these sensors are very stable, high accuracy, maintenance-free, no drift and no need to calibrate, response quickly, etc.. They are mainly designed for medical ventilator oxygen concentration measurement with high flow range up to 80L and for the large PSA generator.

Working Principle:

Ultrasonic concentration detection theory: when the binary gas mixture composition has molecular weight difference, sound travel speed varies from different gas composition, so as obtain binary gas concentration.

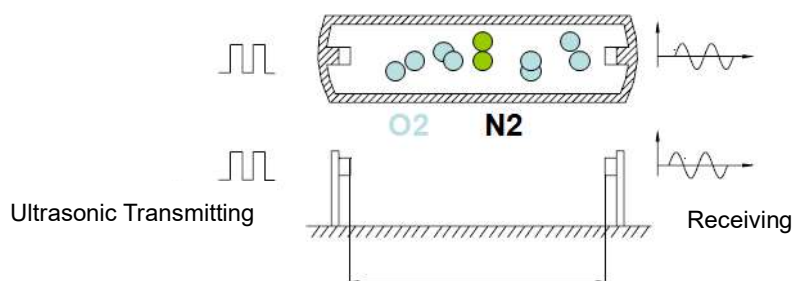

Main Feature:

- ✧ Diffusion and principle of ultrasonic measurement adopted to oxygen concentration measurement
- ✧ Used for oxygen concentration detection of large flow ventilator, mainstream, no need by-pass design
- ✧ Full scale matrix temperature and humidity compensation
- ✧ Quick response, stable measurement, high accuracy
- ✧ Self-calibration, maintenance-free, no drift
- ✧ Perfect EMC performance, long life span,
- ✧ Support serial port and analog output accurate measurements
- ✧ RoHS, REACH, CMC, CE certificated

Specifications

Ultrasonic Oxygen Sensor Specifications			
Sensor Type	Gasboard-8500D	Gasboard-8500D-P	Gasboard-8500D-RH
Detection Method	Ultrasonic Principle		
Detection Range^①	20.5 ~ 95.6%	20.5%-100%	20.5 ~ 95.6%
Detection Accuracy	±3%FS @ (5~45)°C		
Detection Resolution	0.1%		
Response Time	<10s		
Working Temperature	5~50°C; 0~95%RH (non-condensing)		
Storage Temperature	-20~60°C; 0~95%RH below (non-condensing)		
Working Voltage	DC 4.75-12.6V		
Average Working Current	<50mA		
Communication	UART_TTL (3.3V)		
Dimension	L60.7*W26*H30 mm		
Life Span	≥5 years		

Remark^① Oxygen concentration detection range 20.5%~95.6% is calibrated with PSA oxygen source.

If use 99.99% pure oxygen as oxygen source, should add a coefficient to make a transfer, the formula is: Target concentration = (sensor reading * 1.142) - 3.42

Oxygen concentration detection range 20.5%-100% is calibrated with 99.99% pure oxygen.

The reading value<20.5% is off as default, please contact Cubic if necessary.

Pin Definition

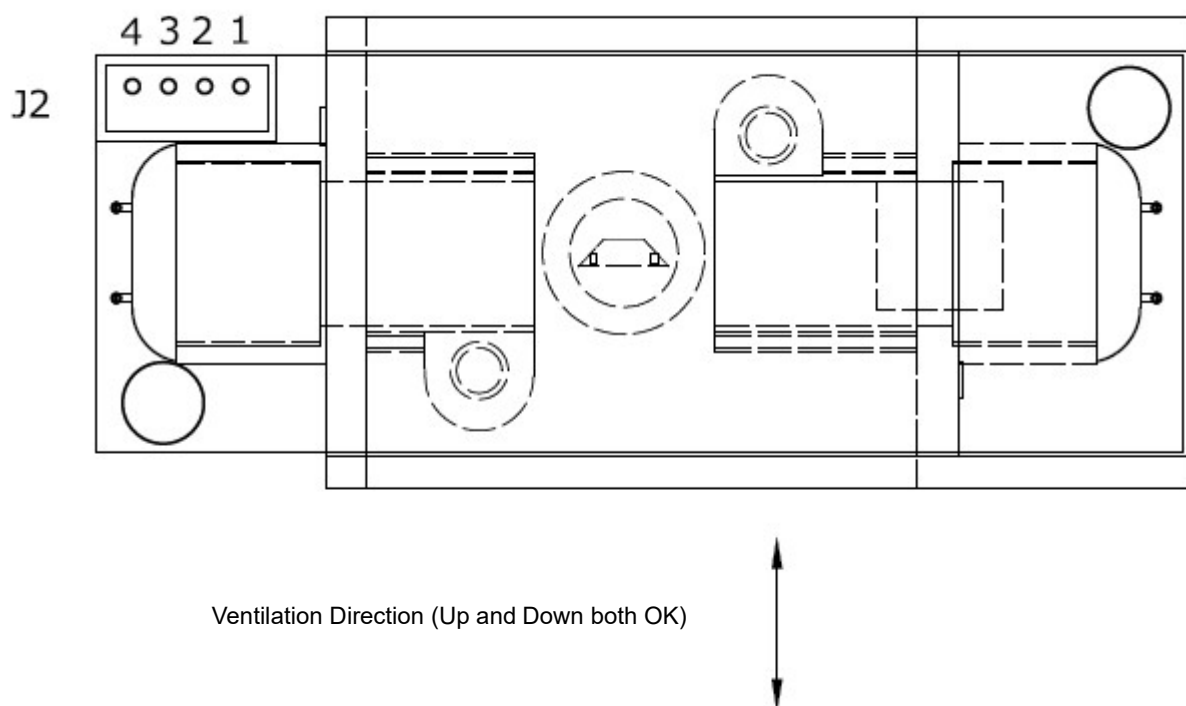

Drawing 1 Gasboard-8500D Series Pin Definition Drawing

Pin Definition

NO	Pin	Description
1	VIN	4.75-12.6VDC power supply input
2	Rx	UART-Rx receiving (3.3V/5V compatible)
3	Tx	UART -Tx sending (3.3V)
4	GND	GND

Connector Type

Port	Terminal	Connector	Pin Pitch
J2	PH2.0-4A	PH2.0-4P	2.0mm

Reference Circuit

Application Scenarios: UART TTL serial output

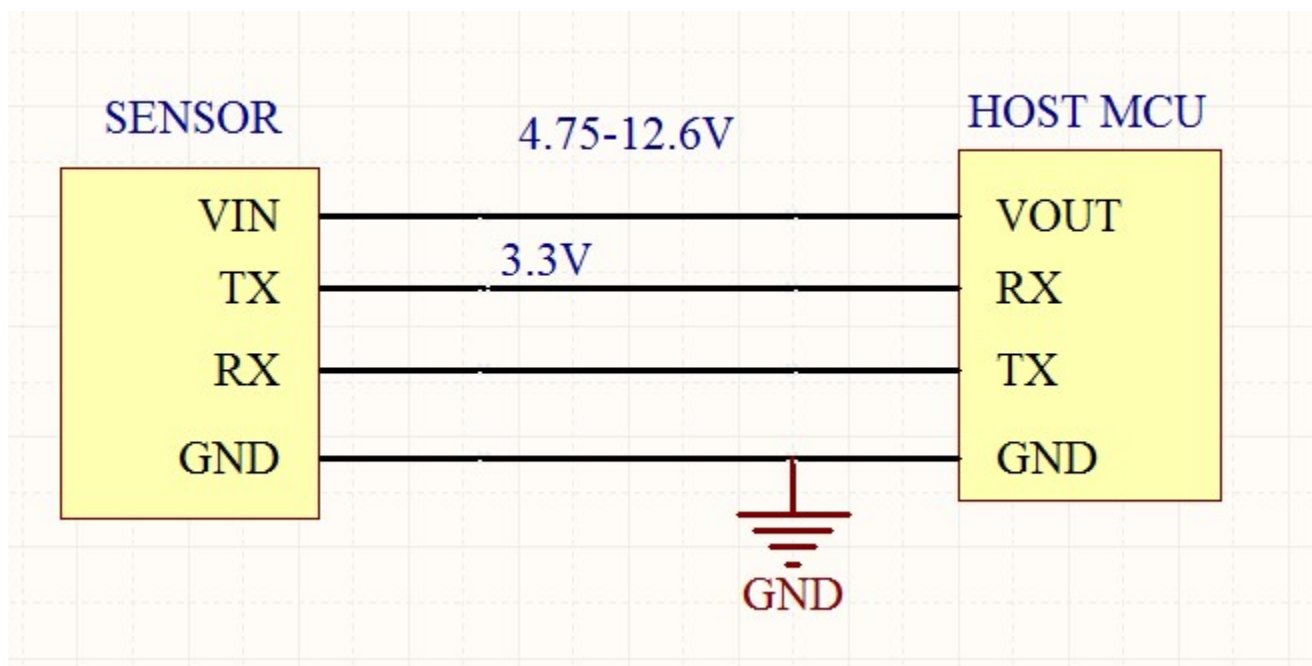

Drawing 2 UART Communication Connection Circuit

Communication Protocol

◆ UART Communication Protocol

1 Protocol overview

- 1) Baud rate:9600, Data Bits: 8, Stop Bits: 1, Parity: No, Flow Control: No
- 2) The protocol data are hexadecimal data. For example, "46" is [70] in decimal;
- 3) [xx] is single byte data(unsigned,0-255); In double byte, the high byte is in front of low byte;
- 4) The default is active sending, and the sending cycle is 0.5 seconds. If you need to read more other data, send the corresponding command directly to the host, and the host responds immediately.

2 Serial communication protocol formats

PC send format

Start symbol	Length	Order No	Data 1	Data n	Checksum
HEAD	LEN	CMD	DATA1	DATA _n	CS
11H	XXH	XXH	XXH	XXH	XXH

Protocol format description

Protocol format	Description
Start Symbol	PC sending is fixed to [11H], module response is fixed to[16H]
Length	Length of frame byte,=data length+1 (include CMD+DATA)
Order No	Directive number
Data	Read or written data, the length is variable
Checksum	The sum of data accumulation, =256-(HEAD+LEN+CMD+DATA)

3 Serial protocol order number list

No	Function name	Order no
1	Read the measurement result of O2	0x01
2	Read the software version number	0x1E
3	Inquiry instrument serial number	0x1F
4	Open reading value<20.5%	0x02

4 Detailed description

4.1 Read the measurement result of O2

Send: 11 01 01 ED

Response: 16 09 01 DF1-DF8 [CS]

Function: Read the measurement result of O2

Explanation: O2 concentration = (DF1*256 + DF2) / 10 (Vol %)

O2 temperature value = (DF5*256 + DF6) / 10 (°C)

Attention: DF3 DF4 DF7 DF8 reserved

Remark: The default is active sending. The sensor can also output the value automatically without sending the command.

When send 11 01 07 E7, can change active data sending mode to request-response mode.

Communication Protocol

Response example:

Response: 16 09 01 00 CD 00 00 00 C2 00 1E 33

Explanation:

Hexadecimal convert into decimal: CD is 205; C2 is 194

O2 concentration = $0 \times 256 + 205 = 205$ (20.5%)

O2 temperature value = $0 \times 256 + 194 = 194$ (19.4°C)

4.2 Read the software version number

Send: 11 01 1E D0

Response: 16 09 1E DF1-DF8 [CS]

Function: read version number for module firmware

Explanation: DF1-DF8 refers to the ASCII code of particular version number.

For example: when module version number is 0.02.611, response data:

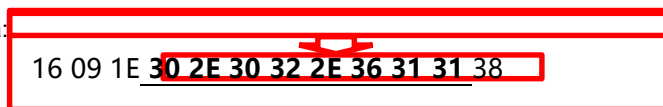

Hexadecimal convert into ASCII code:

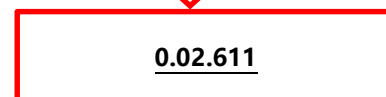

4.3 Inquiry instrument serial number

Send :11 01 1F CF

Response :16 0B 1F (SN1) (SN2) (SN3) (SN4) (SN5) [CS]

Function: read version number for module firmware

Explanation: instrument serial number of output software. SNn range is 0~9999,5 integer type constitute 20 serial number.

4.4 Open reading value<20.5%

Send: 11 02 02 00 EB

Response: 16 0C 02 00 DF1 DF2 DF3 DF4 DF5 DF6 DF7 DF8 DF9 DF10 [CS]

Function: Read the measurement result of O2 (0-100%)

O2 flow = $(DF9 \times 256 + DF10) / 10$ (L/min)

O2 concentration = $(DF7 \times 256 + DF8) / 10$ (Vol %)

O2 temperature = $(DF5 \times 256 + DF6) / 10$ (°C) (gas temperature in Sensor chamber)

Example:

Response: 16 0C 02 00 5D 90 5D 7E 00 C2 00 CD 00 00 7B

Instruction:

Hexadecimal Convert into Decimal: CD is 205; C2 is 194

O2 Concentration = $0 \times 256 + 205 = 205$ (20.5%)

O2 Flow Value = $0 \times 256 + 0 = 0$ (L/min)

O2 Temperature Value = $0 \times 256 + 194 = 194$ (19.4°C)

Dimension

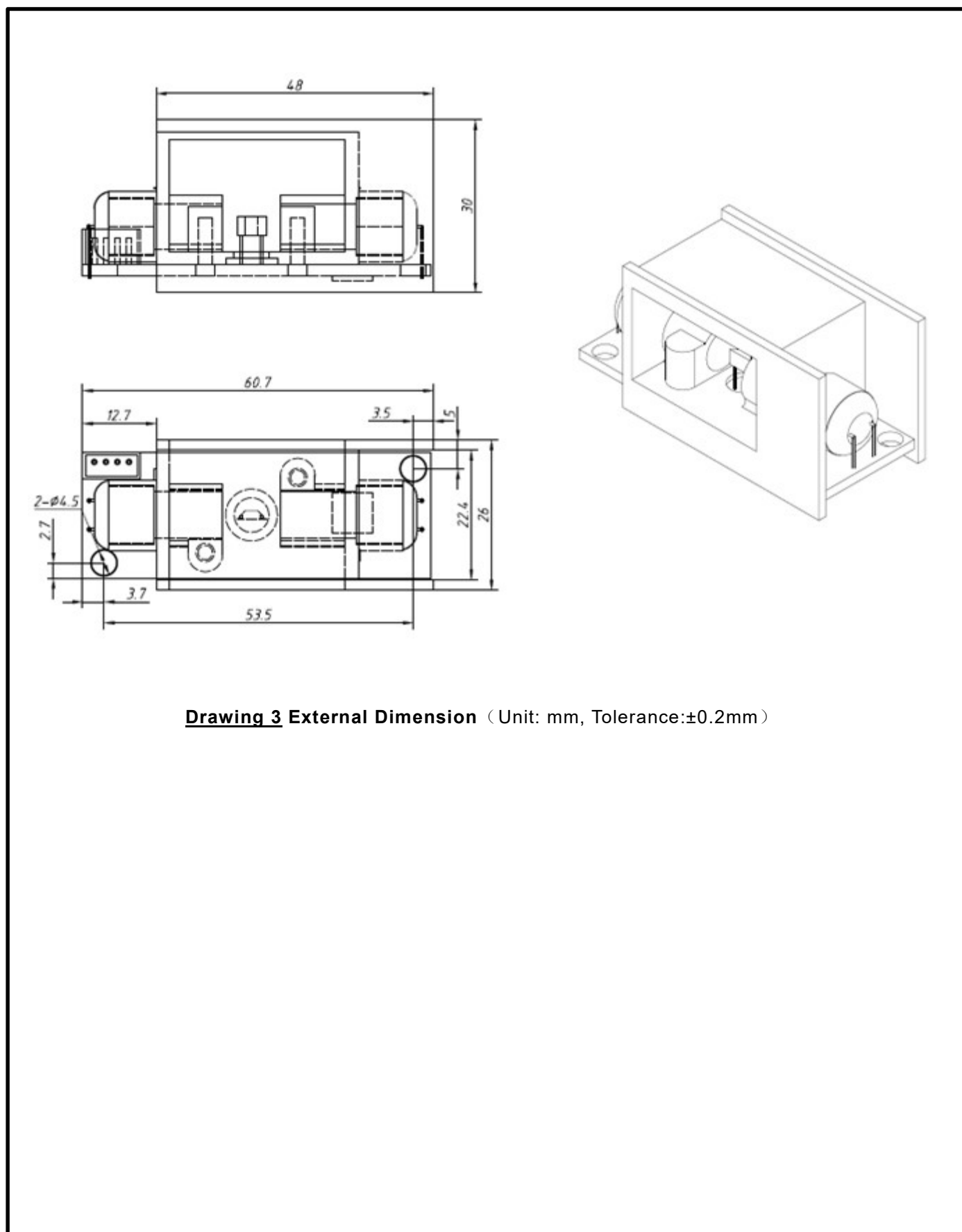

Drawing 3 External Dimension (Unit: mm, Tolerance:±0.2mm)

Reliability Testing

Item	Requirement	Criterion	Sample (n) Failed (c)
Flow performance	Indoor temperature requirement: $25 \pm 2^{\circ}\text{C}$, humidity $(50 \pm 10)\%$ RH, after the sensor connect with serial port and power on, switchover the flow in 3L/min、5L/min、8L/min respectively to make measurement of oxygen concentration and accuracy.	Make new tests in different oxygen flow all can meet error criterion.	n=70 c=0
Low temperature storage	Storing the sensor for 96H with no power under $-20^{\circ}\text{C} \pm 2^{\circ}\text{C}$ environment condition, then to test the measuring error of it under normal temperature condition.	After staying under normal temperature condition for 2 hours, the test all can meet error criterion.	n=0 c=0
Cold operation	Indoor temperature requirement: $-10 \pm 2^{\circ}\text{C}$, to test the measuring error of sensor under normal temperature condition after operating for 96H with electricity.	After staying under normal temperature condition for 2 hours, the test all can meet error criterion.	
High temperature storage	Storing the sensor for 96H with no power under $60^{\circ}\text{C} \pm 2^{\circ}\text{C}$ environment condition, then to test the measuring error of it under normal temperature condition.	After staying under normal temperature condition for 2 hours, the test all can meet error criterion.	
Hot operation	Indoor temperature requirement: $50 \pm 2^{\circ}\text{C}$, to test the measuring error of sensor under normal temperature condition after operating for 96H with electricity.	After staying under normal temperature condition for 2 hours, the test all can meet error criterion.	
High-low temperature shock	Keep the sensor under -20°C for 60 mins, then switch it to 60°C in 10s and stay for another 60 mins, this is one cycle, there are 10 cycles in total, the sensor is power off when testing.	After staying under normal temperature condition for 2 hours, the sensor accuracy should meet the specification standard.	
High temp & humidity	Place the sensor under high temp & humidity ($40 \pm 2^{\circ}\text{C}$, 95%RH), after working under rated voltage for 500H, to test the measuring error of it under normal temperature condition.	After staying under normal temperature condition for 2 hours, the sensor accuracy should meet the specification standard.	n=2 c=0
Salt spray test	Standard :GB/T2423.17, place the sensor in the salt fog box under 35°C and spray it with Nacl solution (concentration is 5%) for 24 hours, then flushing it with distilled water and drying it with airflow.	Keep the sensor under standard environment more than 1 h and less than 2 h, it should no appearance defect, no corrosion.	
Vibration test	Bare sensor should bear the specified vibration test in X/Y/Z direction, frequency range 10~55~10Hz/min, amplitude 1.5mm, scan circulation 2 hours.	No appearance defect after vibration test, the sensor can meet basic performance test standard.	n=4 c=0
Package drop test	Drop height: setting the height as specified weight according to standard GB/T 4857.18. Making the drop test according to the GB/T4857.5 standard. Test sequence is one corner, three edges, six sides.	No appearance defect after drop test, no components fall off, the sensor should work normally.	n=1 ctn c=0

Product Code Instruction

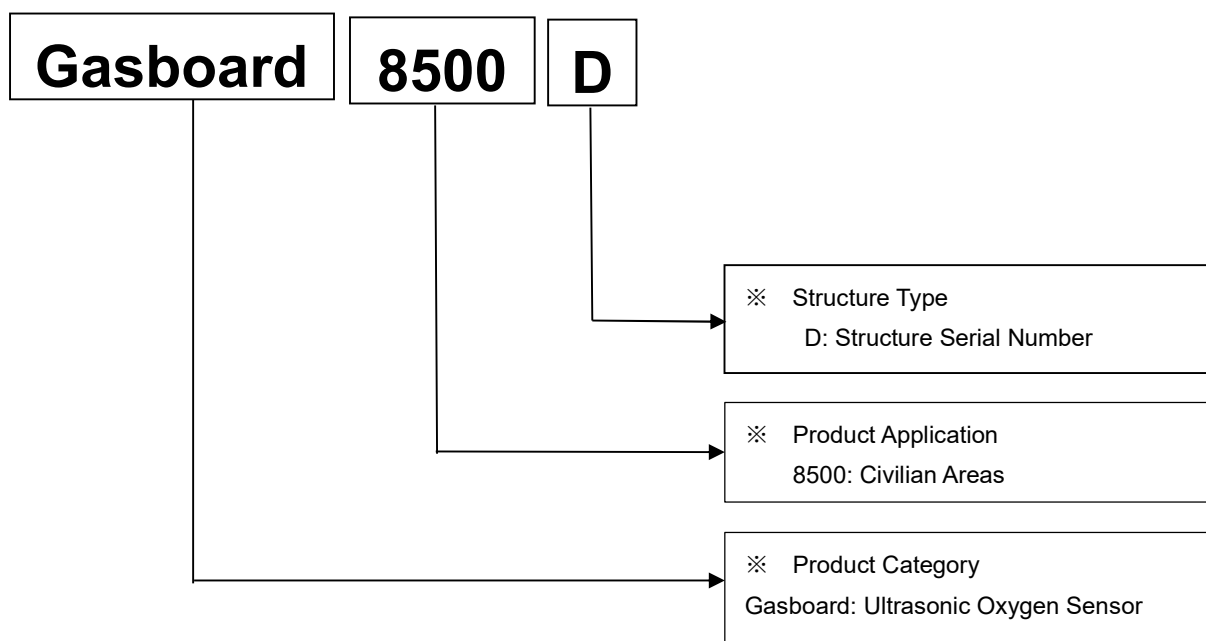

User Attention

Please pay attention to below:

- (1) Install the sensor as far away as possible from the heat source and heat dissipation outlet of the compressor, and install the sensor as close as possible to the oxygen outlet, and install a one-way valve to prevent the water from humidifying glass from entering sensor.
- (2) In order to ensure reliability and long service life, do not use or store the sensor in a place where the temperature is higher than the rated temperature, and do not use the sensor in an environment where the voltage is higher than the rated voltage of the sensor.
- (3) Without necessary compensations, please do not use the sensor in the environments of high humidity water steam, abnormal pressure, and low temperature.
- (4) The product shall not be used or stored in a place with corrosive gas, especially hydrogen sulfide gas, acid, alkali, salt or similar. The products stored in the warehouse should be stored in normal temperature and humidity, and avoid direct sunlight.
- (5) When there is a problem with the Cubic's products, please contact Cubic team in time; the sensor must not be disassembled privately, and Cubic will not bear any consequences if it is damaged by disassembled privately.

Consultancy & After-sales Service

Cubic Sensor and Instrument Co., Ltd

Contact number: 86-27-8162 8827

Address: Fenghuang No.3 Road, Fenghuang Industrial Park, Eastlake Hi-tech Development Zone, Wuhan, China

Postal code: 430205 Fax: 8627-8740 1159

Website: <http://www.gassensor.com.cn>

E-mail: info@gassensor.com.cn